

COMPONENT POSITIONING
SUGGESTIONS ONLY
USED IN PROTOTYPE
AS FAR FORWARD AS
HELP ACHIEVE CORRECT
OF C OF G.

IONS ARE
Y AS THEY WERE
E. PLACE SERVO'S
S PRACTICAL, TO
RECT POSITION

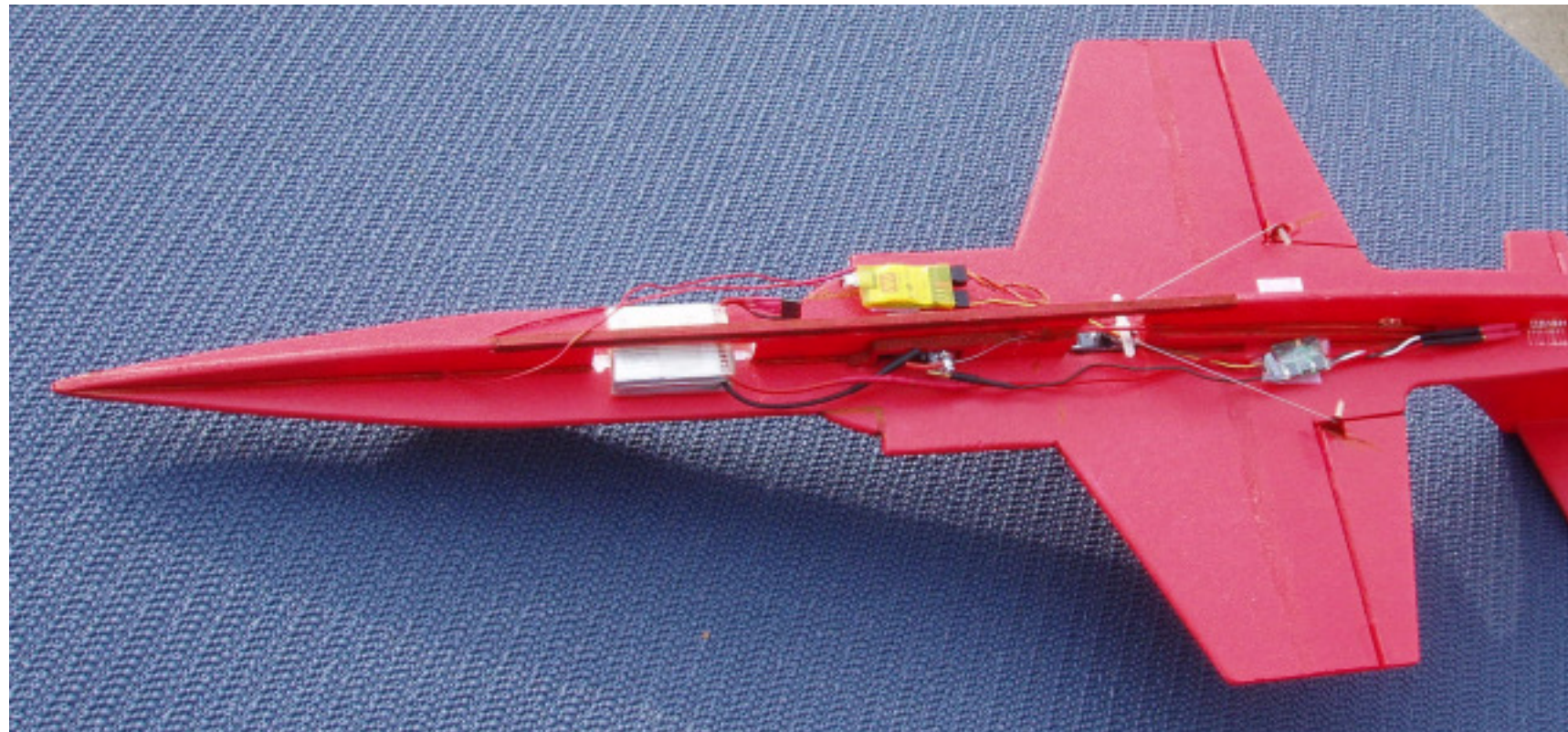



F-104 Starfighter

Material: 5 mm Depron®

Prototype Power: CD-Rommotor 14turn 0.4 mm + LiPo 3s700 E-Tech

Propeller: Gunther 125 x 110

Prototype RTF Weight: 165 grams

Design and Drawing: Willem Bravenboer
Sheet #2: Overview, component placement
and instructions

Copyright 2007 Willem Bravenboer

REVISION V 1.2

CONTROL DEFLECTIONS: AILERONS +/- 15 MM WITH 80% EXPONENTIAL,
OR +/- 6-8 MM IF NO EXPO. ELEVATOR: +/- 8-10 MM, SOME PEOPLE MAY
LIKE UP TO 50% EXPO.

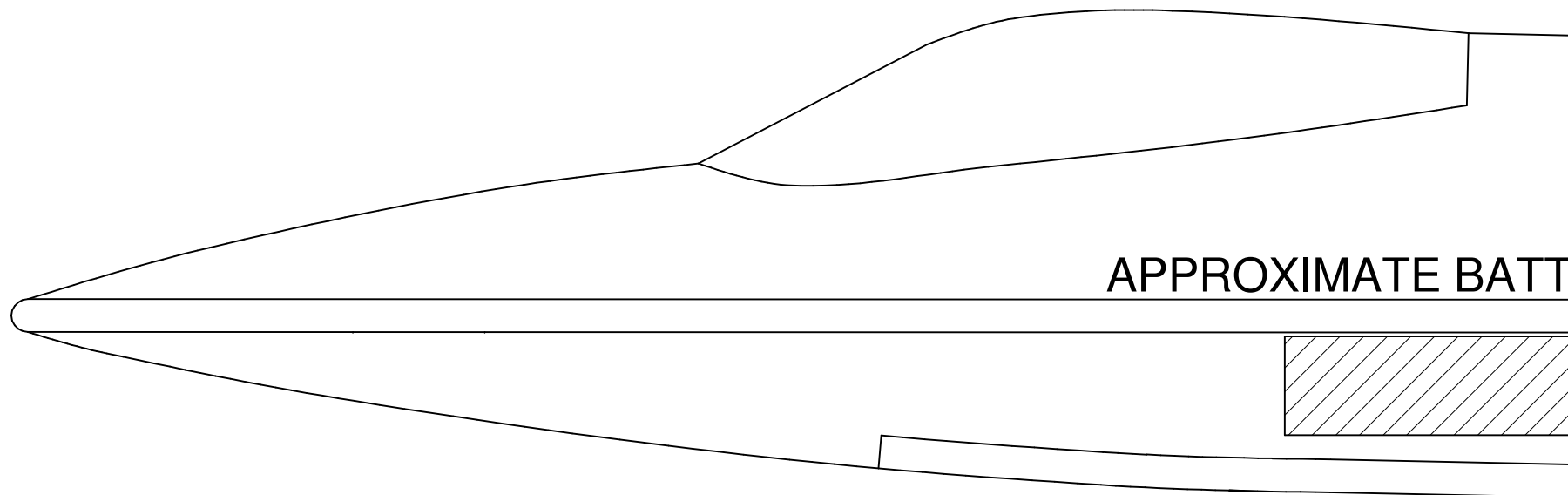

DETERMINE THE BATTERY
AFTER COMPLETING THE
PAINTING AND INSTALLING
THEN CUT THE SLOT FOR
PACK, SLIGHTLY LONGER
BUT TRY TO OBTAIN A FA



SIZE CH

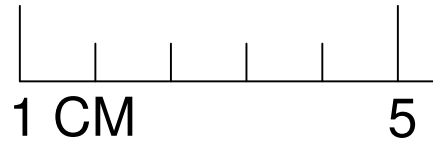

WARNING: PLACING THE CENTER OF GRAVITY FURTHER BACK WILL INDUCE A DEEP STALL WHEN POWER IS REDUCED!

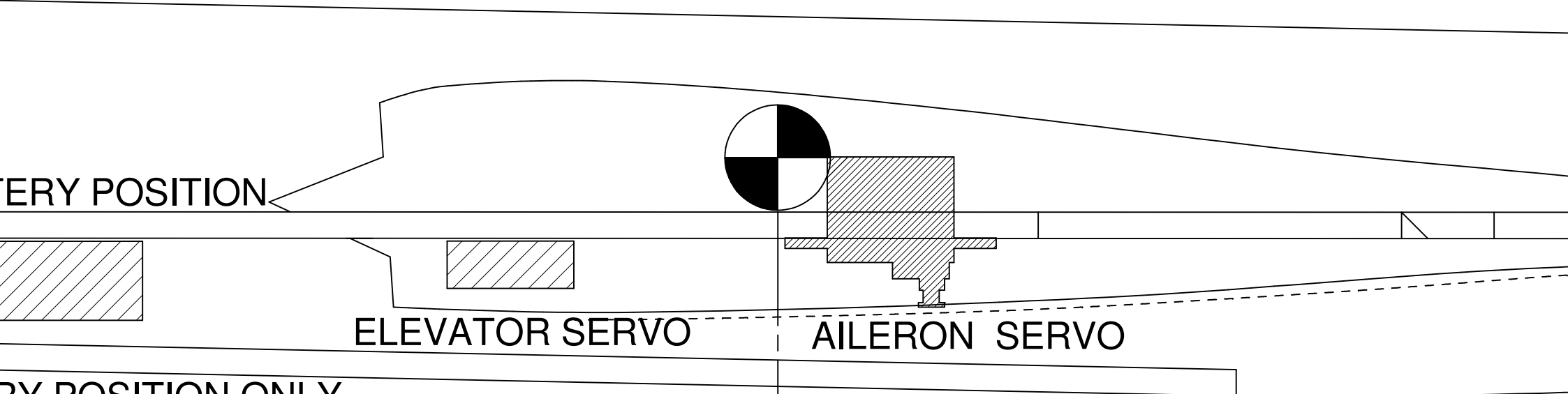

BATTERY POSITION

ELEVATOR SERVO

AILERON SERVO

BATTERY POSITION ONLY
IN THE PLANE, I.E. AFTER
INSTALLING RADIO GEAR ETC.
FOR THE BATTERY
TO BE FURTHER THAN THE PACK,
NEED A VERY AIRY TIGHT FIT.

SU
PU
TU
MM
AN
SU

DECK

CM

10 CM

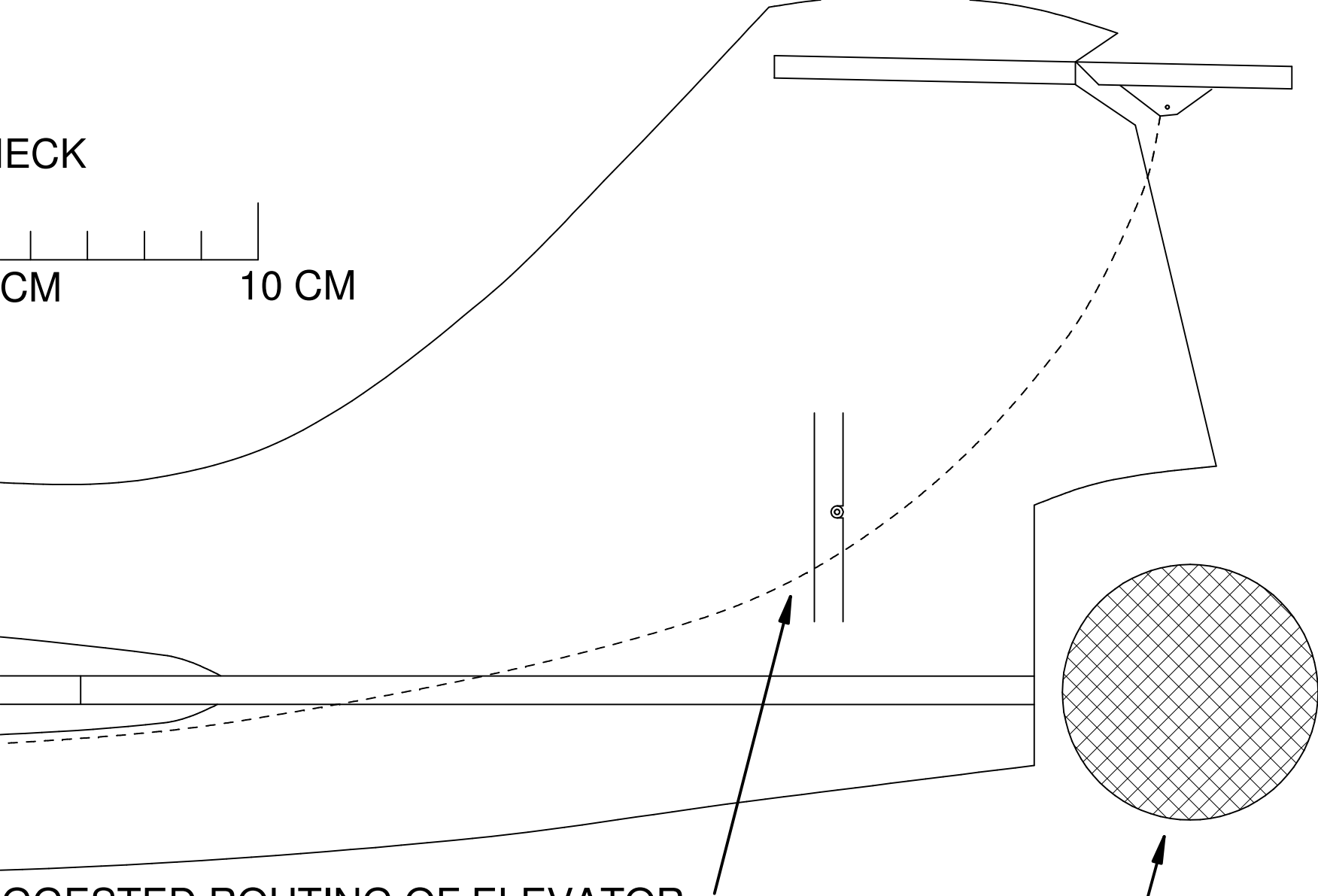

SUGGESTED ROUTING OF ELEVATOR
SHROD. USE 2 MM X 1 MM OUTER
TUBING WITH 0.5 MM PUSHROD. MAKE 2
MM GROOVE INTO ONE SIDE OF DEPRON®
AND MOUNT TUBING FLUSH WITH
SURFACE.

MOTOR: PROTOTYPE USED
CD-ROM MOTOR WITH 14 TURNS OF
0.4 MM WIRE. MOUNT IN YOUR



ELEVATOR SERVO DETAIL

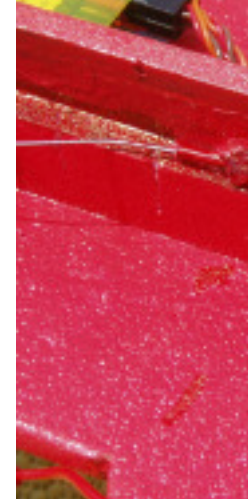

AILERON

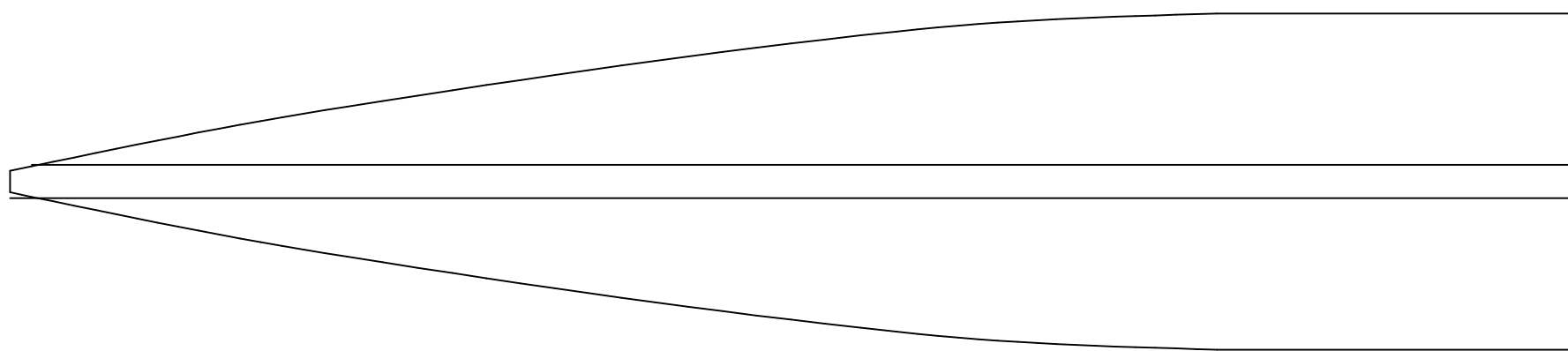

BOTTOM VIEW

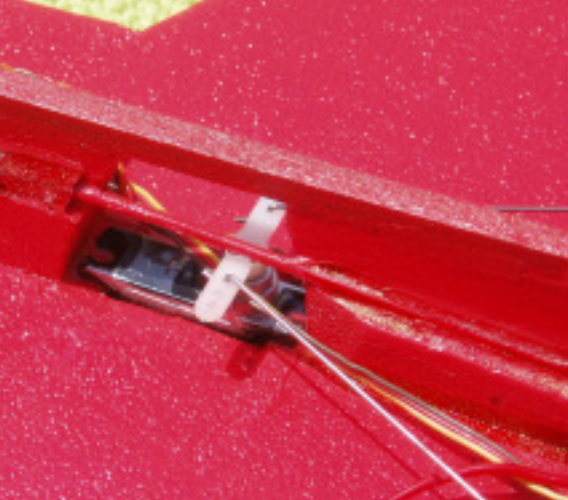

SERVO DETAIL

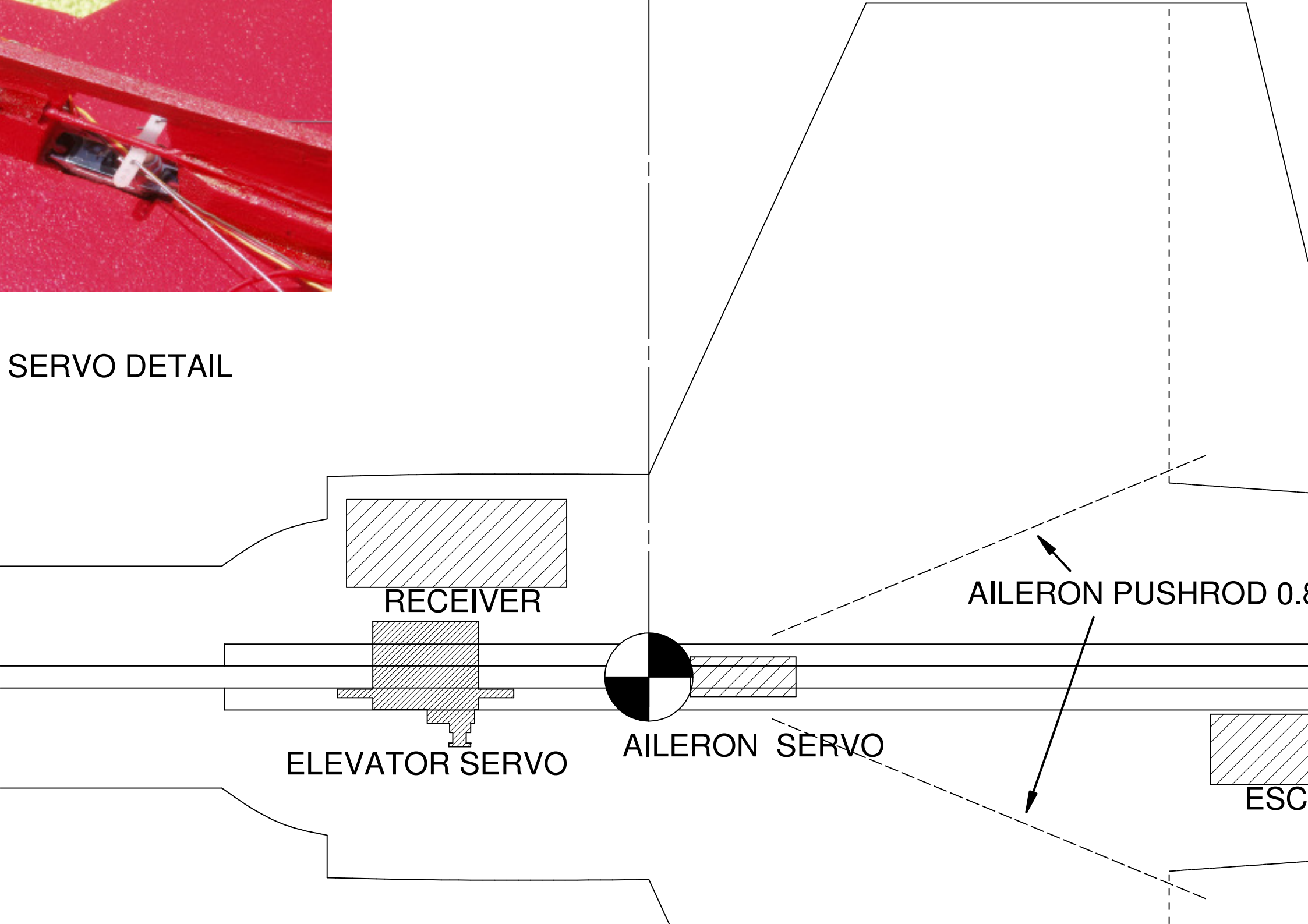

0.4 MM WIRE. MOUNT IN YOUR
PREFERRED MANNER. EASIEST AND
LIGHTEST WAY IS USING TUBE
MOUNT. MOTOR USED IS 20 GRAMS.

BATTERY USED IN PROTOTYPE: 3S700 E-TECH, WEIGHT IS 52 GRAMS.
ESC: CASTLE CREATIONS PHOENIX 10
PROPELLER: GUNTHER 125 X 110

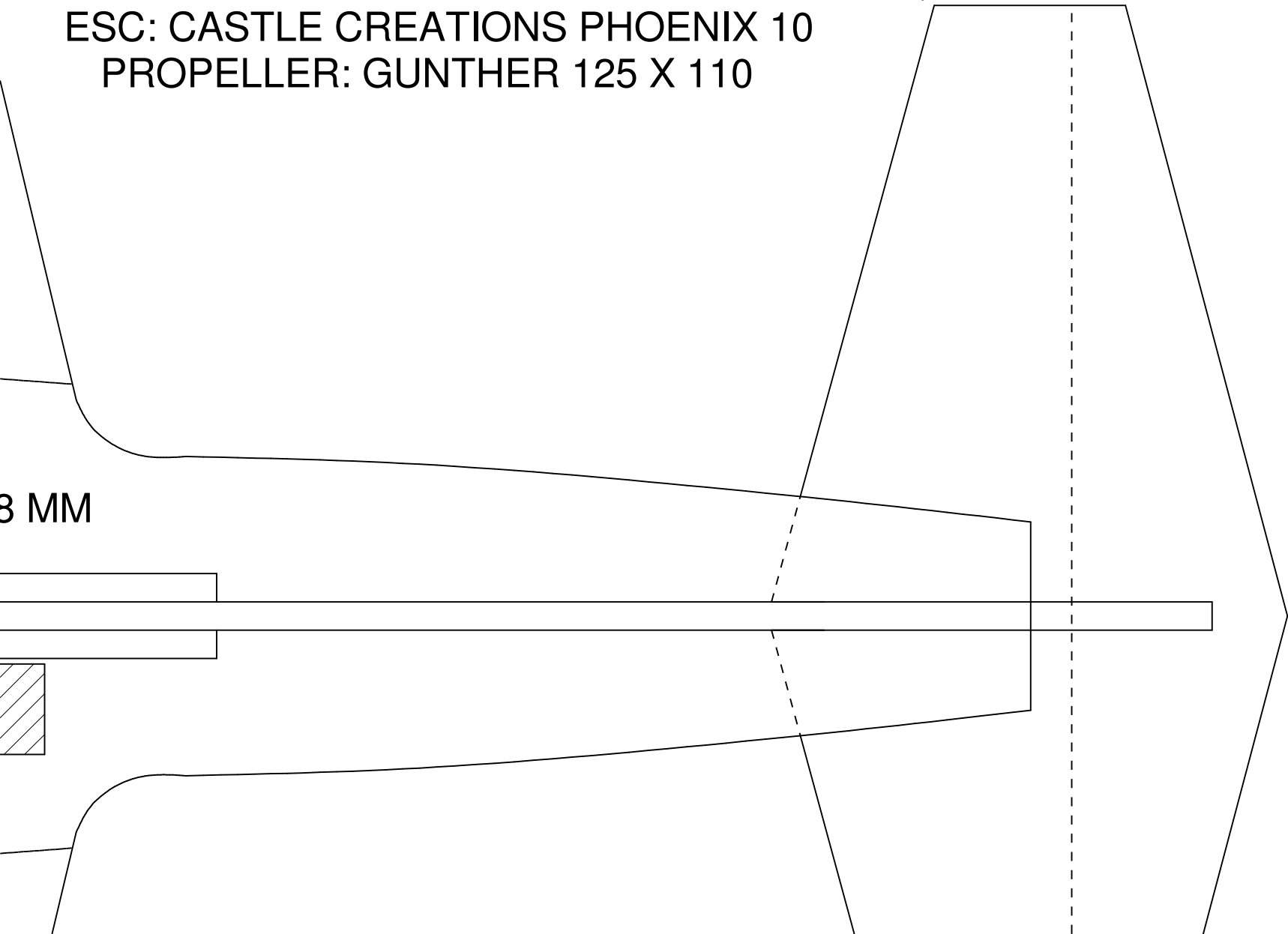

3 MM

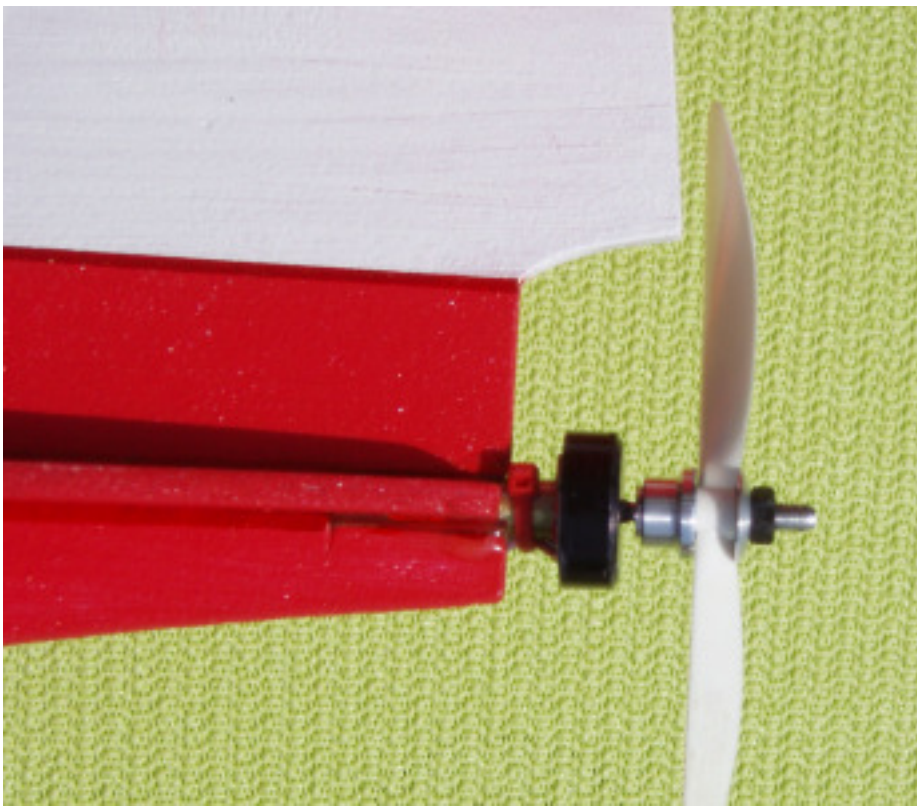

MOTOR DETAIL # 1

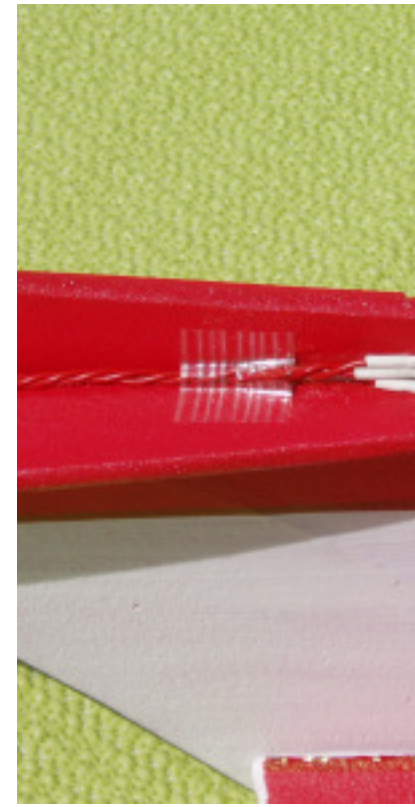

MOTOR DETAIL



2

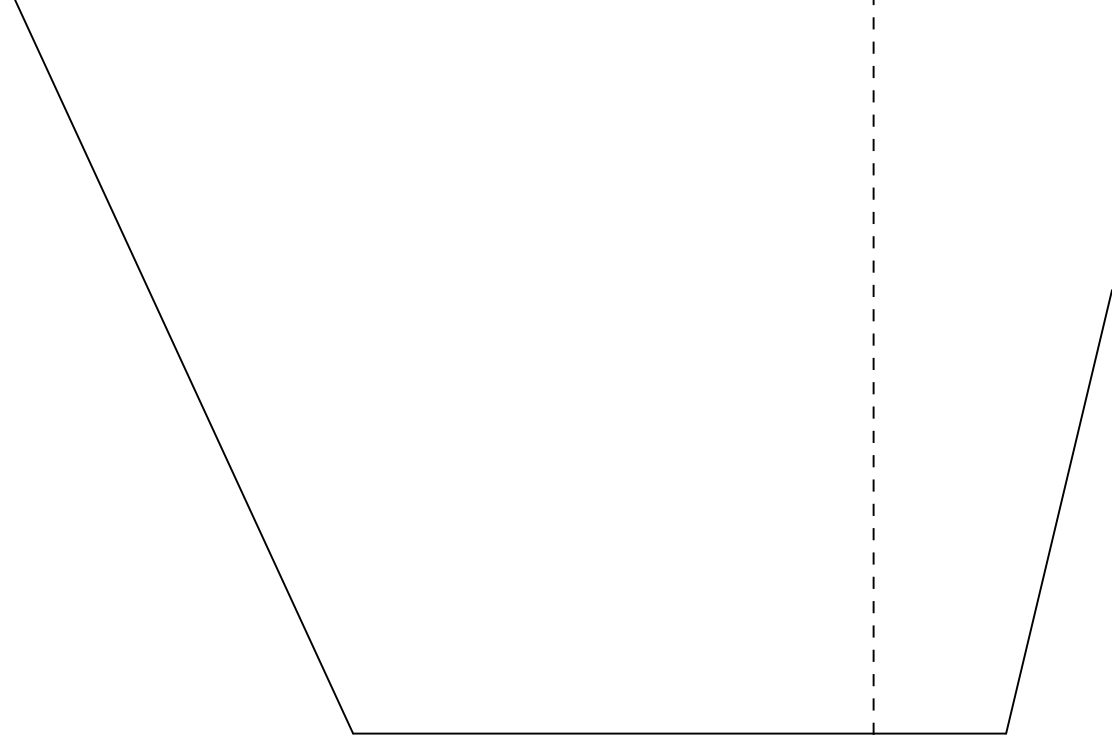

FLYING: CHECK FOR PROPER SENSE OF CONTROL DEFLECTIONS. CHECK FOR CORRECT C OF G - THIS IS CRITICAL! PERFORM A RADIO RANGE CHECK. THIS IS ALSO CRITICAL BECAUSE OF THE LONG ELECTRICAL WIRING! LAUNCH FIRMLY, NOSE SLIGHTLY UP. THIS MODEL IS RELATIVELY EASY TO FLY, BUT THE SHORT WING SPAN CAN MAKE IT DIFFICULT TO SEE. THIS MODEL IS EXTREMELY STABLE, IT IS SELF-RIGHTING AS IF IT HAD A LARGE WING WITH LOTS OF DIHEDRAL.

