

Rotor hub, top view

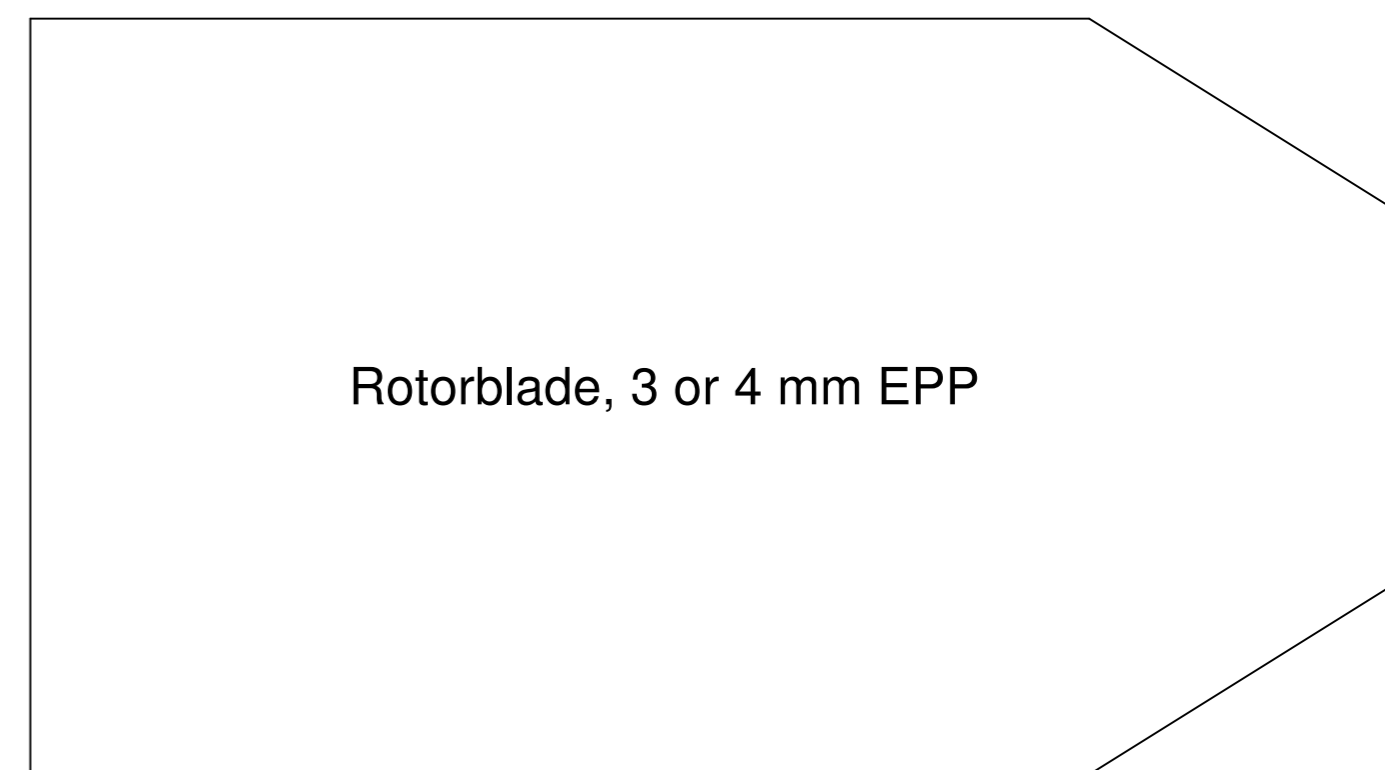

Landing gear 1 mm piano wire

Ensure that the 3 mm x 3 mm balsa strips are positioned bottom left and top right when viewed from above. ROTOR MUST ROTATE CLOCKWISE WHEN VIEWED FROM ABOVE! Bearing is plastic tube, 2 mm inside dia. Tube is 12 mm long and protrudes 2 mm below hub.

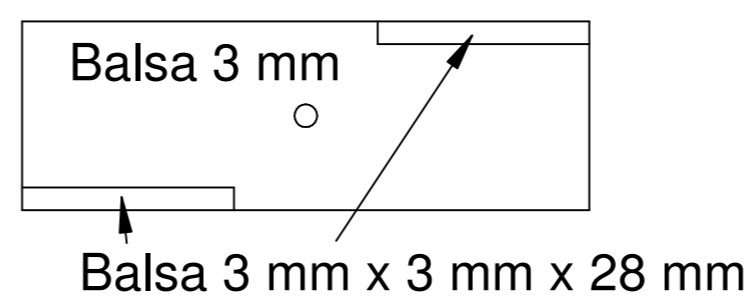
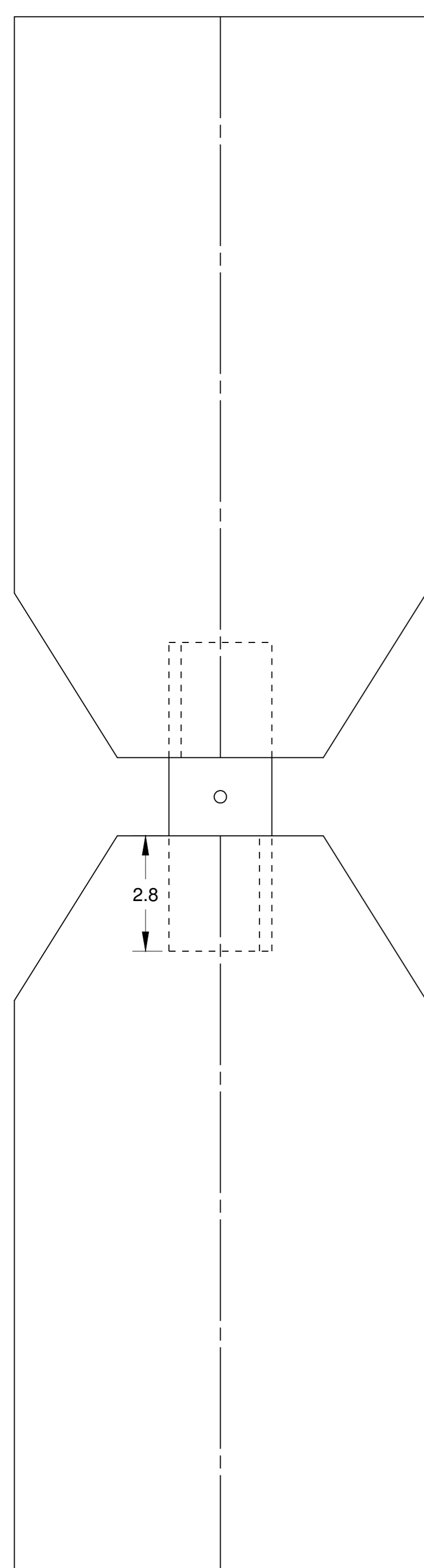

Motor: 5 grams outrunner  
Battery: 2S250 - 2S300  
Servo: 3.7 g or 4.8 g  
Use lightest equipment possible!

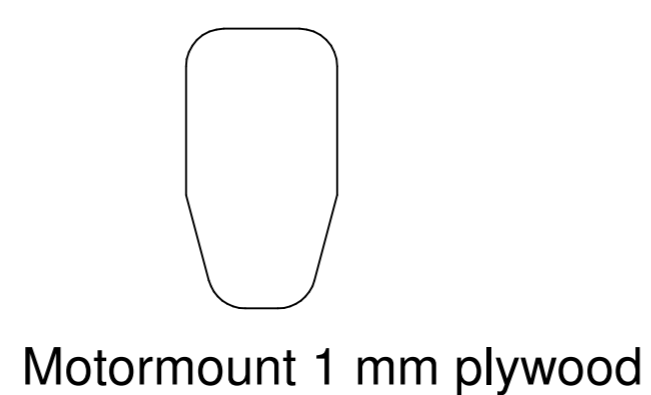
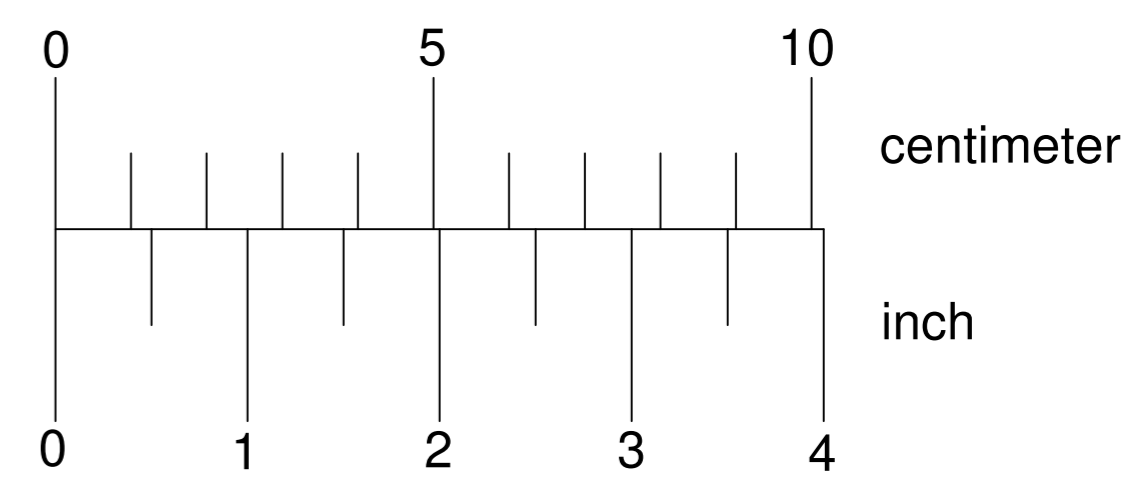
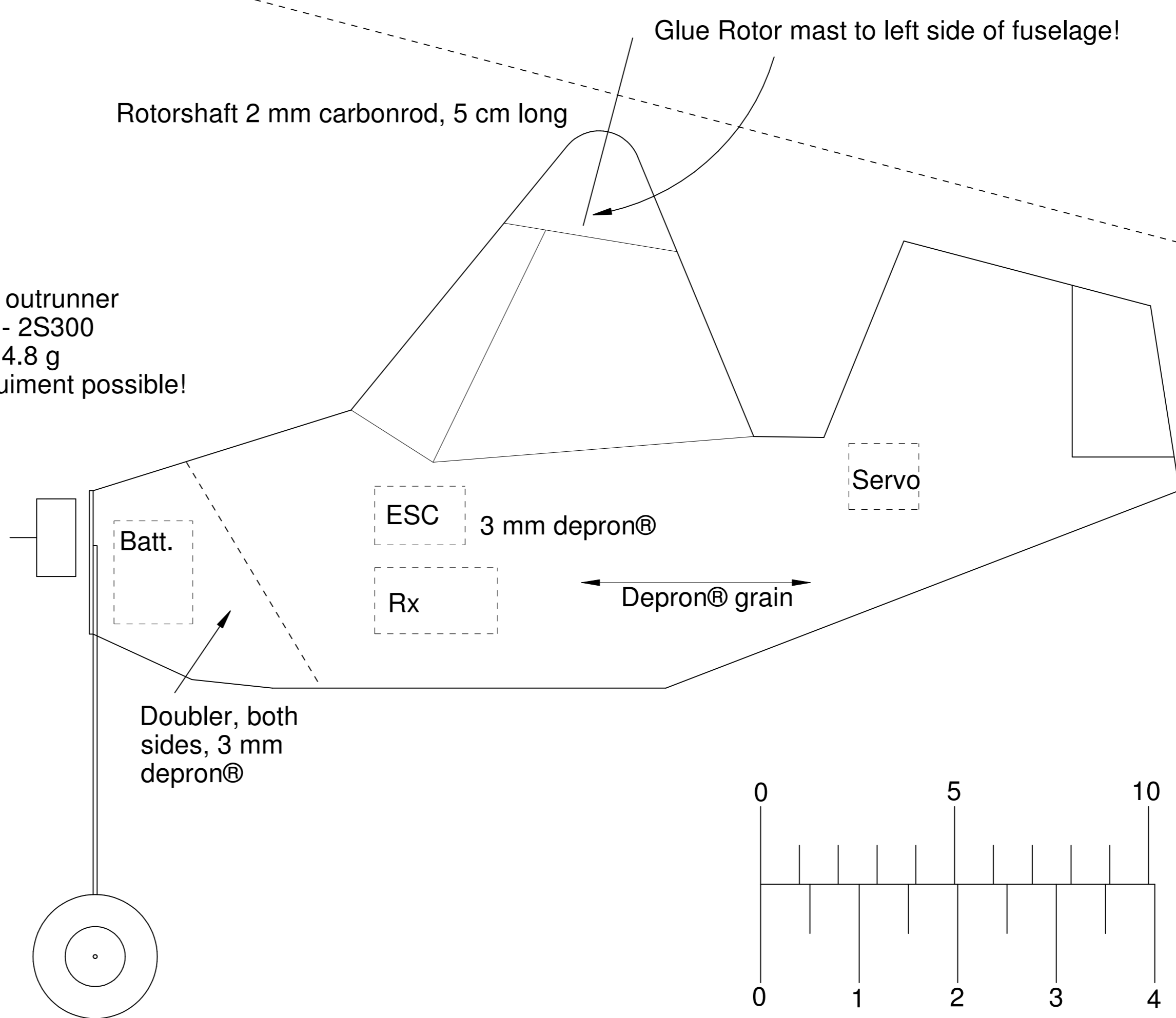

# Micro Gyro Standard

A small, easy to build and very easy to fly autogyro with an extremely high fun factor. 2 Ch. required (throttle and rudder). Target weight approximately 65 grams ready to fly.

Based on a design by Al Foot

Drawing: Willem Bravenboer

© 2008 Willem Bravenboer

REVISION V 1.2 2008-12-05