

Balance:
When holding at rotor mast,
rotor should be pointing
approximately 20° down

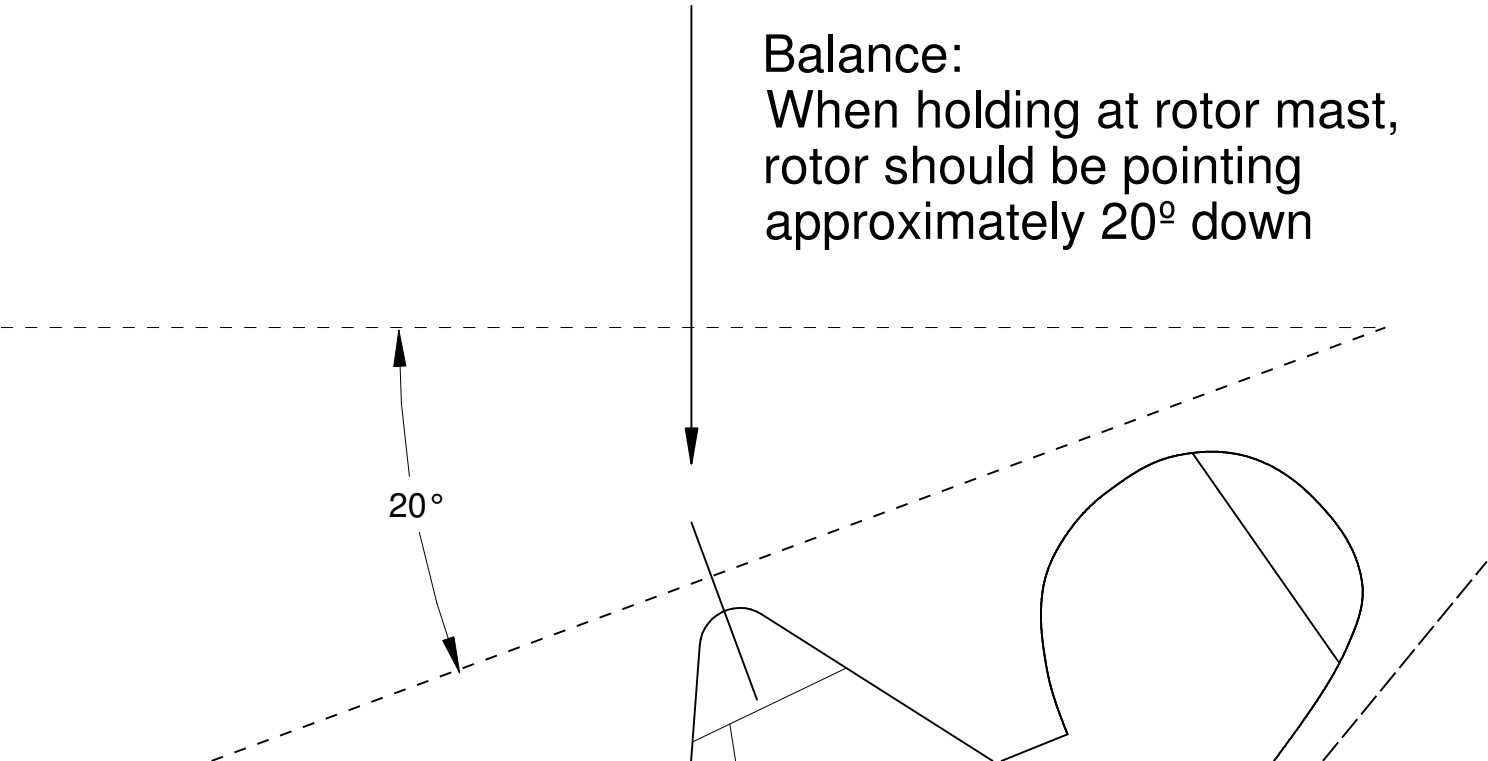

Rotor hub, top



Balsa 3 m

Balsa 3 m

Top view

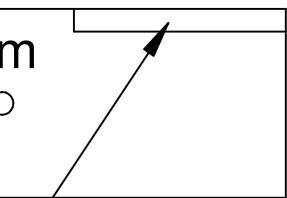

3 mm x 3 mm x 28 mm

Rotorblade, 3 or 4 mm EPP

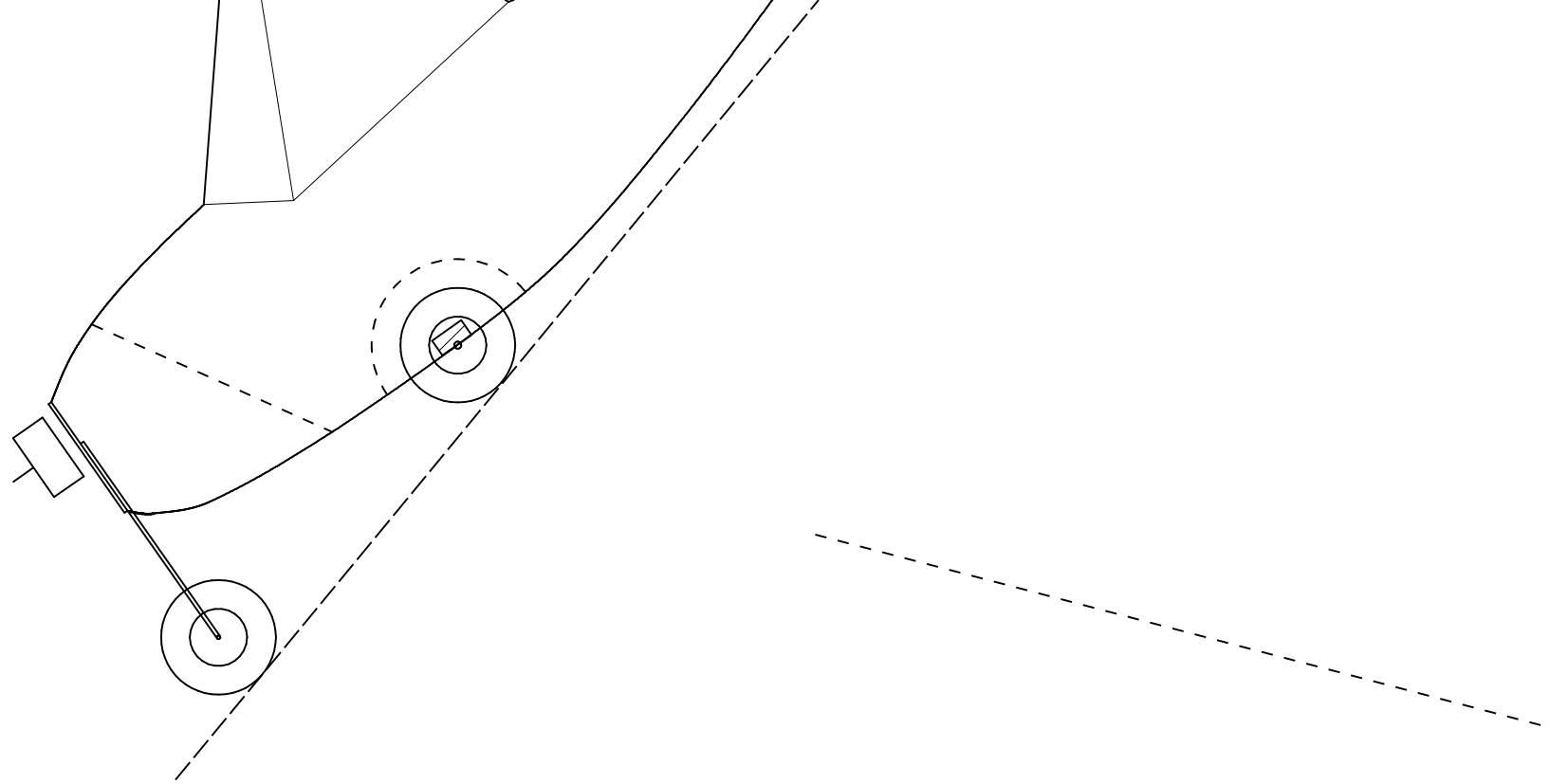

Rotorshaft 2 mm

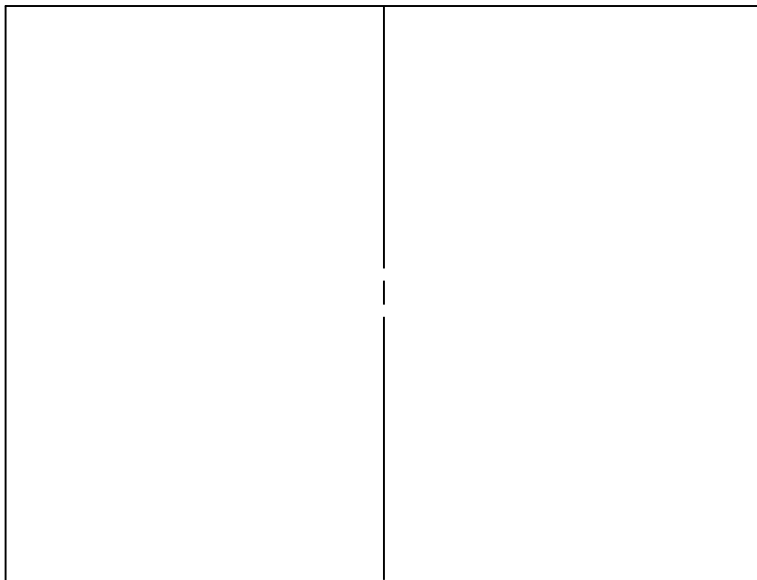

Motor: 5 grams outrunner
Battery: 2S250 - 2S300
Servo: 3.7 g or 4.8 g
Use lightest equipment possible!

Ensure that the 3 mm x 3 mm balsa strips are positioned bottom left and top right when viewed from above. ROTOR MUST ROTATE CLOCKWISE WHEN VIEWED FROM ABOVE! Bearing is plastic tube, 2 mm inside dia. Tube is 12 mm long and protrudes 2 mm below hub.

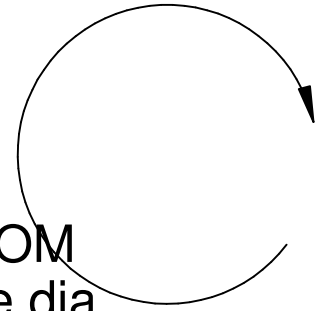

Glue Rotor mast to left side of fuselage!

Carbon rod, 5 cm long

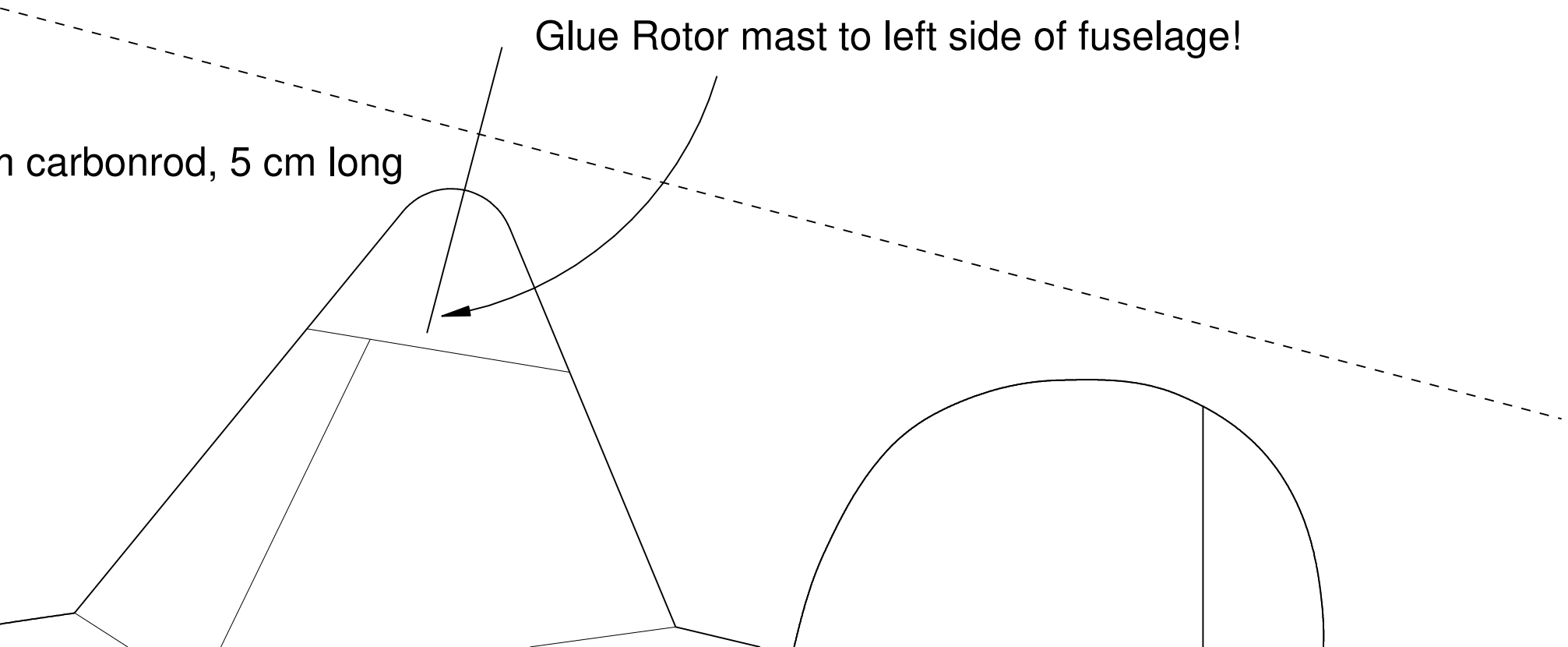

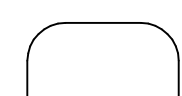
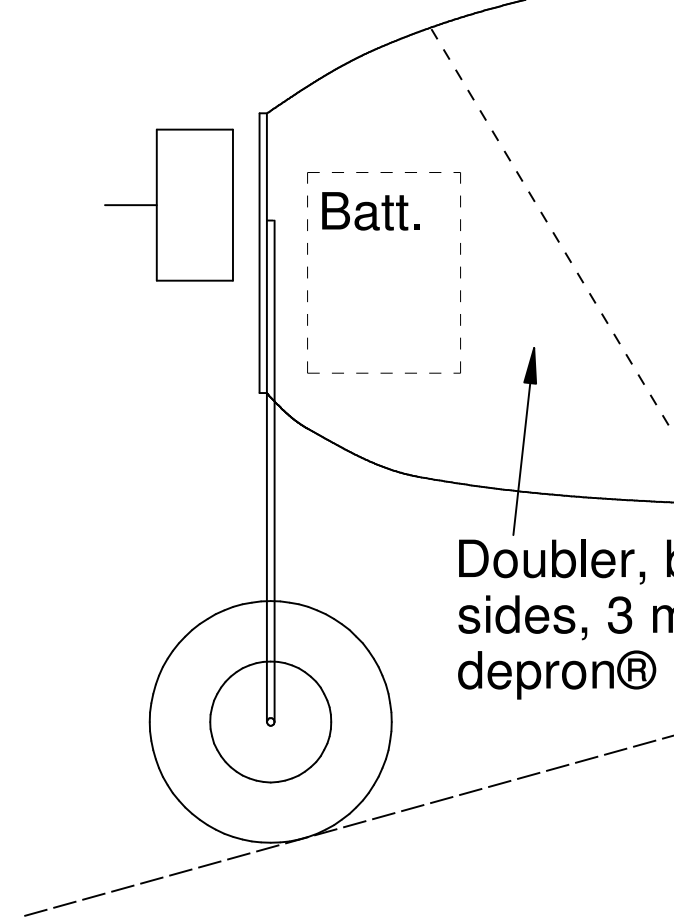
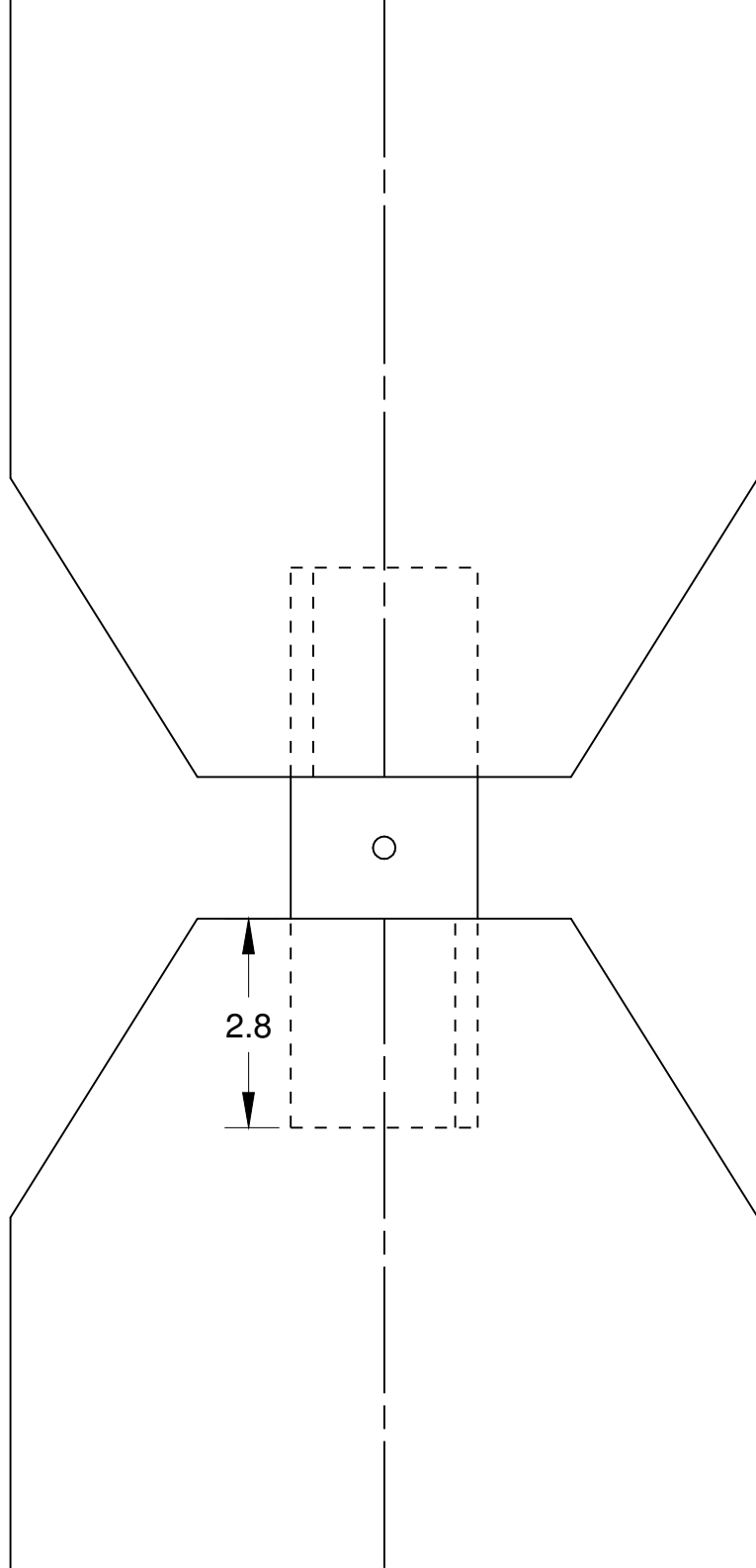

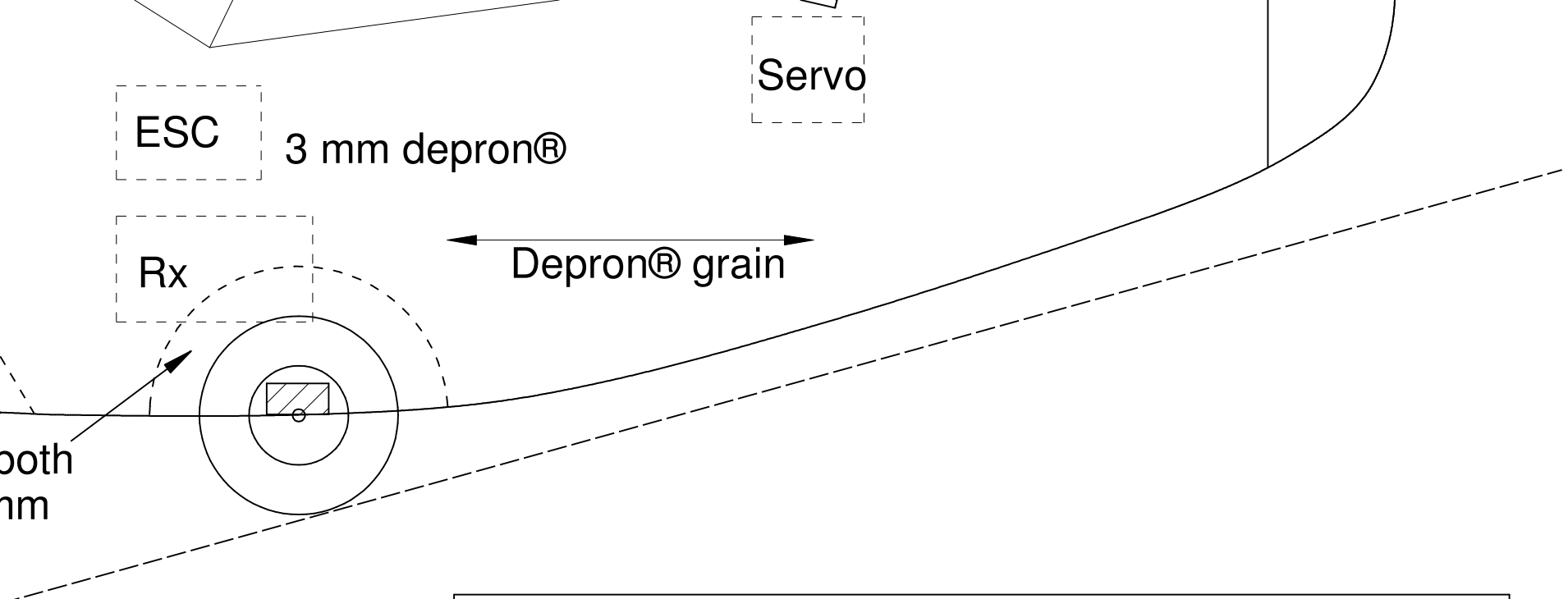

Main gear axle: 1.5 mm carbon rod, 17 cm long

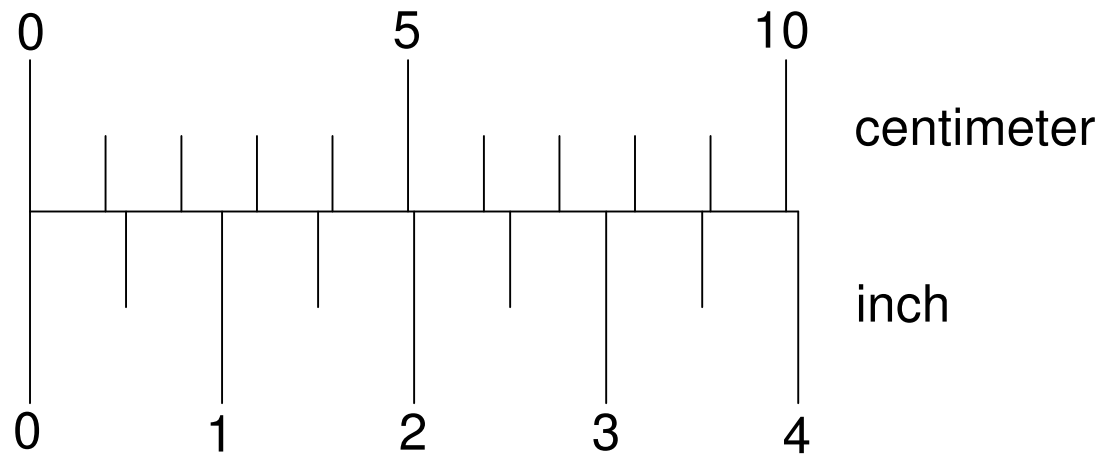

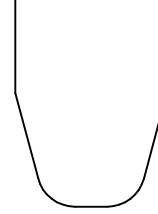
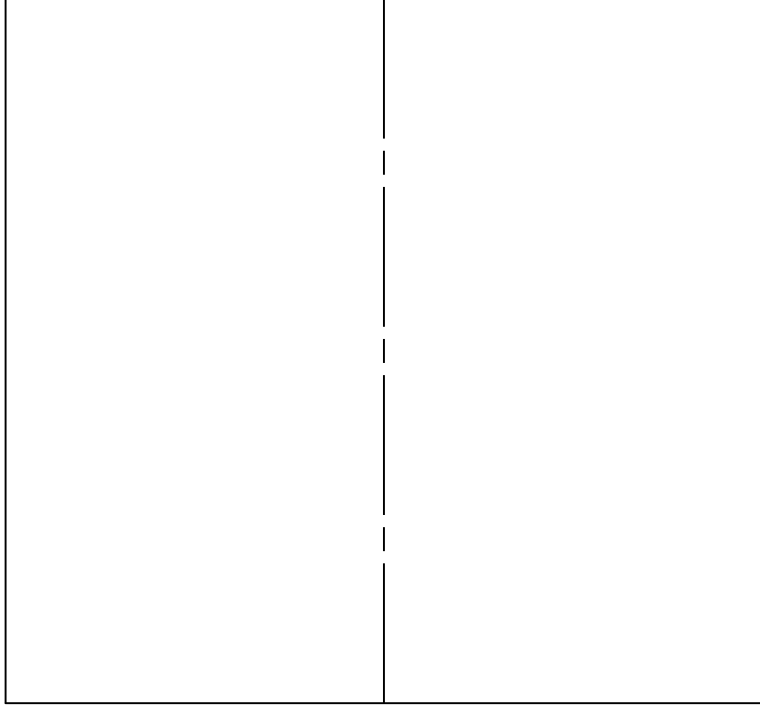

Motormount 1 mm plywood

Micro Gyro Bear - Trike

A small, easy to build and very easy to fly autogyro with an extremely high fun factor. 2 Ch. required (throttle and rudder). Target weight approximately 65 grams ready to fly.

Based on a design by Al Foot

Drawing: Willem Bravenboer

© 2008 Willem Bravenboer

REVISION V 1.0 2008-12-05